

Electric and hybrid propulsion

E-LINE AIR COOLED

050

6,7 kW input peak power
1300 RPM - 40 Nm output

4,9 kW input power
1100 RPM - 36 Nm output

Input voltage 24 VDC



EAIR0502S



MPE1KB



MPE1MBV

EAIR0502S is supplied with

- Swap & Go motor brackets and motor mounts type EMX65
- Integrated thrust bearing
- Mounting flange 4" suitable for Combiflex 12, Bullflex type 1 (see page 95 for couplings and propeller shaft products)
- MPE1KB key switch - all-in-one solution; V-CAN power supply, external 12 VDC power supply and anti-theft, see page 80
- MPE1MBV monitoring panel - V-CAN monitoring, battery indication, motor alarms and motor status, see page 82
- IV2412360 converting 24 VDC to the required V-CAN power supply 12 VDC

Additional components and accessories to upgrade your electric boating experience

- Side-mount V-CAN control levers with different propulsion modes (see page 81)
- Multifunctional display and battery monitoring solutions (see pages 82 and 83)
- Shore power connection set (see page 279)

TECHNICAL SPECIFICATIONS

E-LINE AIR model	050 24
Motortype	Brushless induction motor
CAN bus	V-CAN
Nominal input voltage	24 VDC (20 - 35 VDC)
Maximum input current draw	280 A
Maximum output power	5,5 kW (cf. 11 hp)
Indicative energy consumption*	1,2 kWh @ 4 km/h (3,5 kt)*
Suitable for indicative boat length	up to 6,5 m (21 feet) or 2,5 ton*
Motor output power	4 kW (@1100 rpm) (ISO/DIS 8665-2 as amended)
Maximum shaft rpm in NORMAL mode	1100 rpm
Maximum shaft rpm in ECO mode	1000 rpm
Maximum shaft rpm in POWER mode	1300 rpm
Maximum torque	40 Nm
Transmission ratio	1:1 direct electric drive
Coupling (optional)	Combiflex 1225 / 1230 Bullflex 0125 / 011
IP-rating motor	IP65 with gore-tex membrane and IPx3 cover
Cooling system	Air cooled
Control and warning lights and audible indication on MPE1MBV panel (standard)	Propulsion active, POWER mode, temperature, battery level indication, high current draw, low voltage, limiting alarm
Electric circuit protection	Fuse 300 Amps
Dry weight	68 kg
Equipped with	Active Electronic Braking Battery Protection function Boosted Battery Charge function

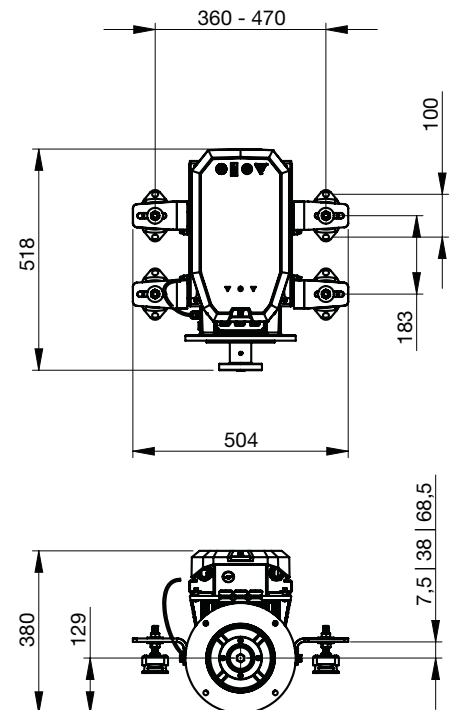

*Indication only. Values strongly depending on hull shape, boat length, weight, propeller pitch/diameter and other parameters.