

# Fresh water systems

## Rigid tanks for fresh water

### Fresh water system type DWSC

#### Comfort 'ready to go' system

This high grade synthetic tank for fresh water is supplied with an electric pump which automatically switches on when the pressure in the system drops (for example when a tap is opened).

#### Specifications

- Tank capacity of 42, 61, 88 and 120 L
- Wall thickness 6,5 mm
- System is available for 12 or 24 VDC
- Pump capacity 13.2 L/min. at zero head
- Connections for filling line Ø 38 mm, outlet line Ø 13 mm and ventilation line Ø 16 mm
- Also supplied with inspection cover, gauge sender, connectors and filter in suction line

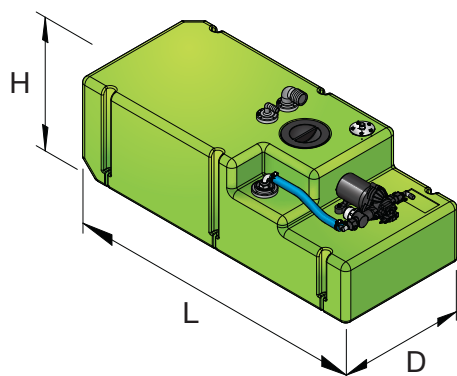

Type	Tank capacity (L)	Voltage (DC)	Ø Filler connection (mm)	Ø Breather connection (mm)	Ø Outlet connection (mm)	Pump capacity (L/min)	Pump pressure (Bar)	L Length (mm)	D Depth (mm)	H Height (mm)
DWSC04212	42	12	38	16	13	13,2	3,1	610	350	400
DWSC04224	42	24	38	16	13	13,2	3,1	610	350	400
DWSC06112	61	12	38	16	13	13,2	3,1	780	350	400
DWSC06124	61	24	38	16	13	13,2	3,1	780	350	400
DWSC08812	88	12	38	16	13	13,2	3,1	930	400	400
DWSC08824	88	24	38	16	13	13,2	3,1	930	400	400
DWSC12012	120	12	38	16	13	13,2	3,1	1050	450	400
DWSC12024	120	24	38	16	13	13,2	3,1	1050	450	400